

DSRM-2600/U

Serial Number

35000001-35999999

Last updated date

16/Jan/2023

TABLE OF CONTENTS

MOTOR	1
GEAR CASE, SHIELD	3
MAIN PIPE, HANDLE.....	5
CONTROL	7
ACCESSORIES	9

MOTOR

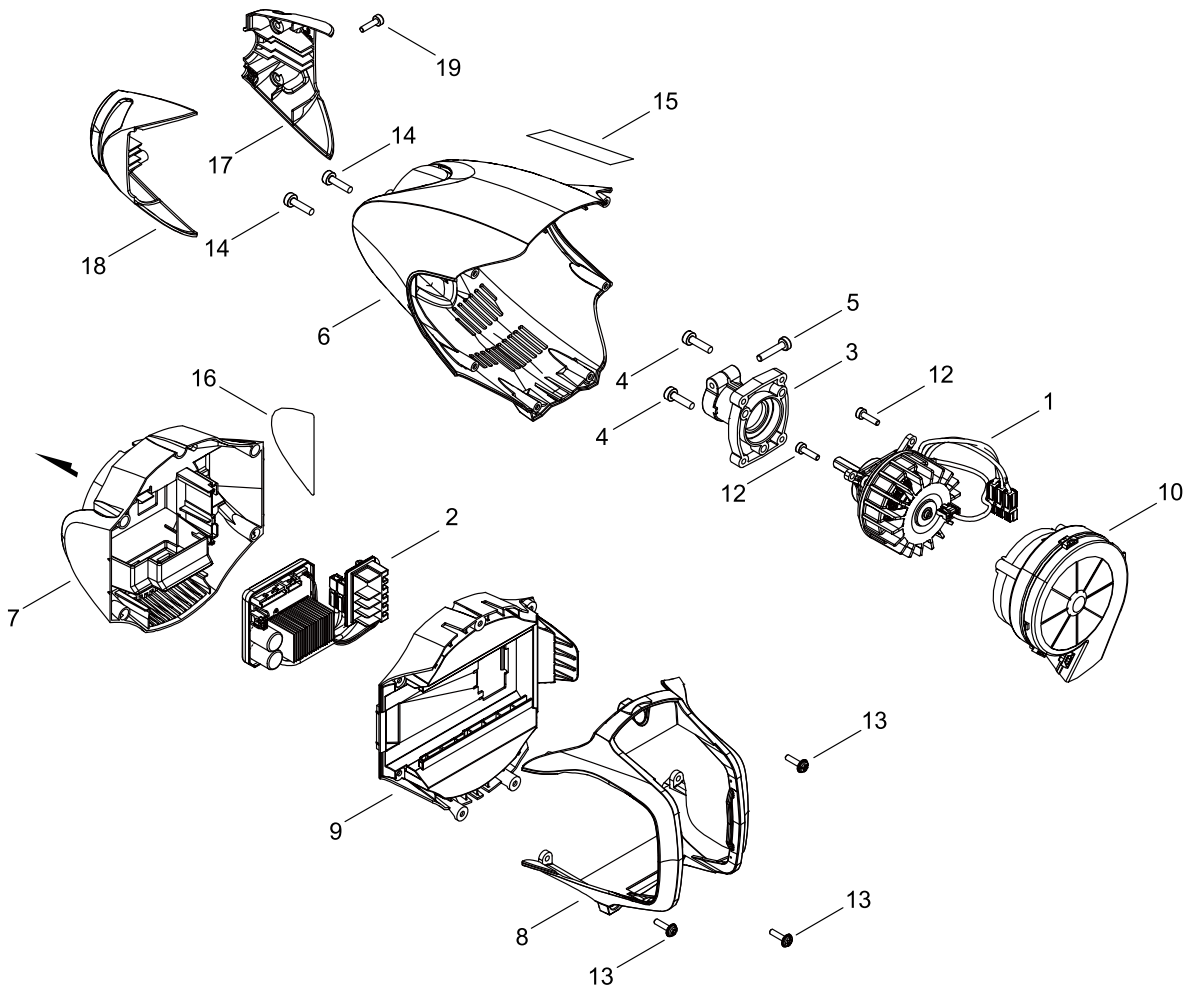

MOTOR

Key No.	LV (+)	Parts Number	Parts Description	Qty	Standard	Class
1		A054-000330	MOTOR,ASM	1		D
2		A047-000450	BOARD,ASM CONTROL	1		D
3		A575-000770	FIXTURE, MAIN PIPE	1		C
4		V805-000160	BOLT, TORX 5	3	TB-5*20 10.9	C
5		V805-000170	BOLT, TORX 5	1	TB-5*25 10.9	C
6		A539-000490	COVER,MOTOR	1		C
7		A161-000440	DUCT, AIR	1		C
8		C145-000190	COVER,BATTERY	1		D
9		C146-000030	HOLDER,BATTERY	1		D
10		P021-054020	CASE,FAN ASY	1		C
12		V804-000170	BOLT, TORX 4	3	TT-P 4*16	C
13		V804-000190	BOLT, TORX 4	7	TT-P 4*16	C
14		V805-000160	BOLT, TORX 5	4	TB-5*20 10.9	C
15		X502-000390	LABEL,ECHO	1	ECHO 72.5*15	D
16		X503-015940	LABEL,MODEL	1	DSRM-2600	D
17		X424-000080	FIXTURE,COVER	1		C
18		X424-000090	FIXTURE,COVER	1		C
19		V804-000170	BOLT, TORX 4	2	TT-P 4*16	C

Class : Consumable class

A:Fast moving parts B:Semi-fast moving parts C:Slow moving parts D:Order only as needed

GEAR CASE, SHIELD

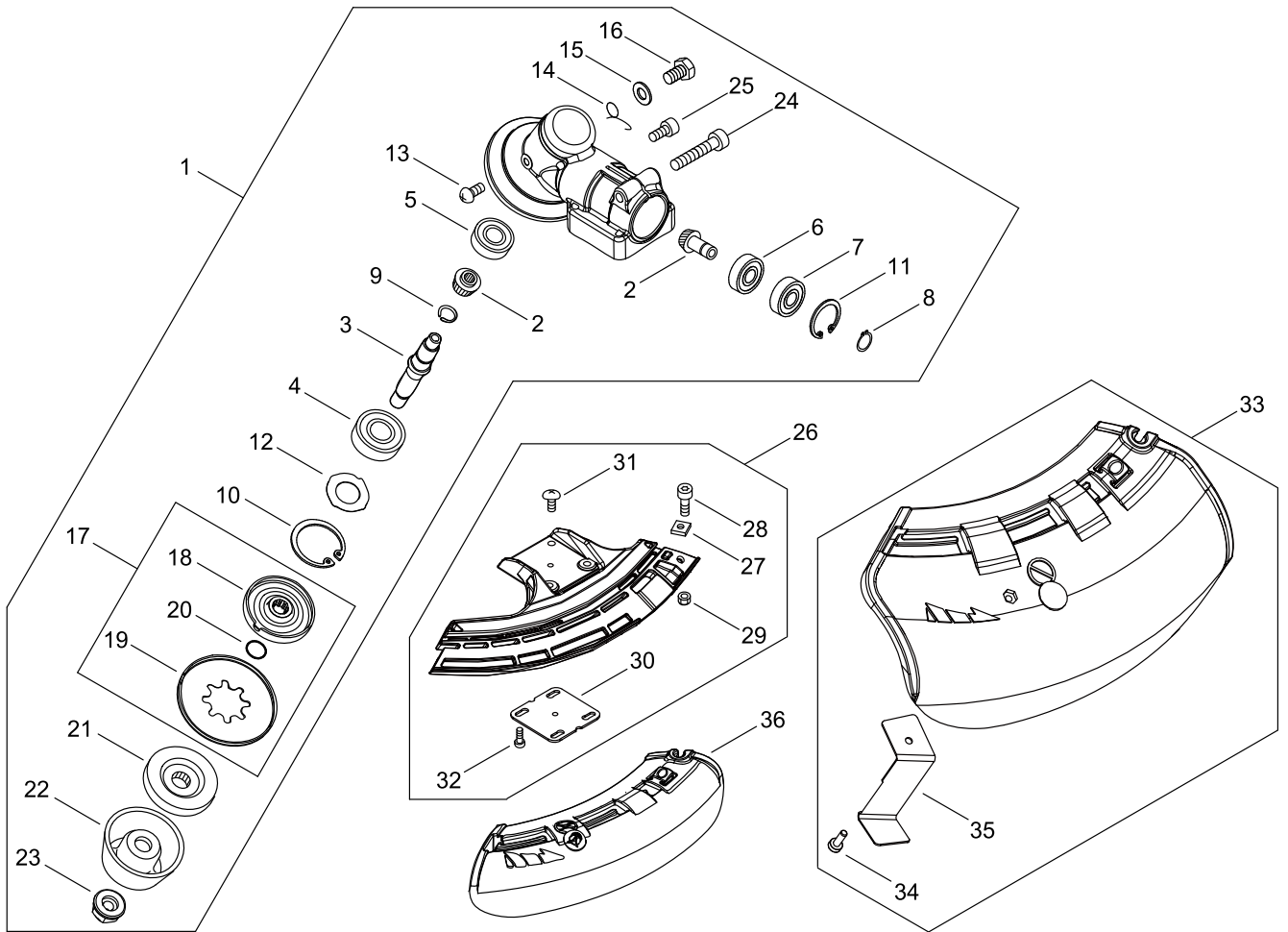

GEAR CASE, SHIELD

Key No.	LV (+)	Parts Number	Parts Description	Qty	Standard	Class
1		P100-004840	CASE,GEAR ASY	1		
2	++	V000-000260	GEAR SET, BEVEL	1		D
3	+	C534-001080	SHAFT, GEAR	1		D
4	+	900812-06201	BEARING, BALL	1	6201LLU(DDU)	
5	+	900810-00629	BEARING, BALL	1	629	
6	+	900800-00609	BEARING, BALL	1	609	
7	+	900803-00609	BEARING, BALL	1	609Z	
8	+	900701-00009	RETAINING RING	1	CS-9	
9	+	900706-00012	RETAINING RING	1	WR-12	
10	+	900702-00032	RETAINING RING	1	CR-32	
11	+	900702-00025	RETAINING RING	1	CR-25	
12	+	V340-000180	WASHER	1		C
13	+	900220-04006	SCREW	1	4*6	
14	+	V452-001310	SPRING,TORSION	1		B
15	+	900603-50008	WASHER	1	8.5*18*0.8T	C
16	+	610434-50031	BOLT 8* 8	1	M8*8	B
17	+	610313-52932	FIXTURE,BLADE	1		B
18	++	610313-52132	FIXTURE,BLADE	1		C
19	++	610352-56830	PLATE, CUP	1		B
20	++	900720-00012	O-RING	1	P-12	
21	+	610314-52130	PLATE, ADAPTER (L)	1		B
22	+	699229-56830	PLATE, COVER	1		B
23	+	610320-52130	NUT 10	1		B
24	+	V806-000020	BOLT, TORX 6	1	TB-6*25 10.9	C
25	+	V805-000130	BOLT, TORX 5	1	TB-5*10 10.9	C
26		P100-010520	SHIELD ASY	1		B
27	+	900565-00005	NUT, SQUARE	1	5	
28	+	V805-000170	BOLT, TORX 5	1	TB-5*25 10.9	C
29	+	900562-00005	NUT, LOCK	1	5	
30	+	C552-000200	PLATE, SHIELD	1		D
31	+	91316-04010	SCREW	1	4*10	C
32	+	V805-000260	BOLT, TORX 5	4	TB5*25 10.9	C
33		P100-010830	SHIELD ASY	1		B
34	+	V805-000150	BOLT, TORX 5	1	TB-5*16 10.9	C
35	+	C554-000090	KNIFE, CORD	1	16INCH	B
36		C550-000551	SHIELD,BLADE	1		B

Class : Consumable class

A:Fast moving parts B:Semi-fast moving parts C:Slow moving parts D:Order only as needed

MAIN PIPE, HANDLE

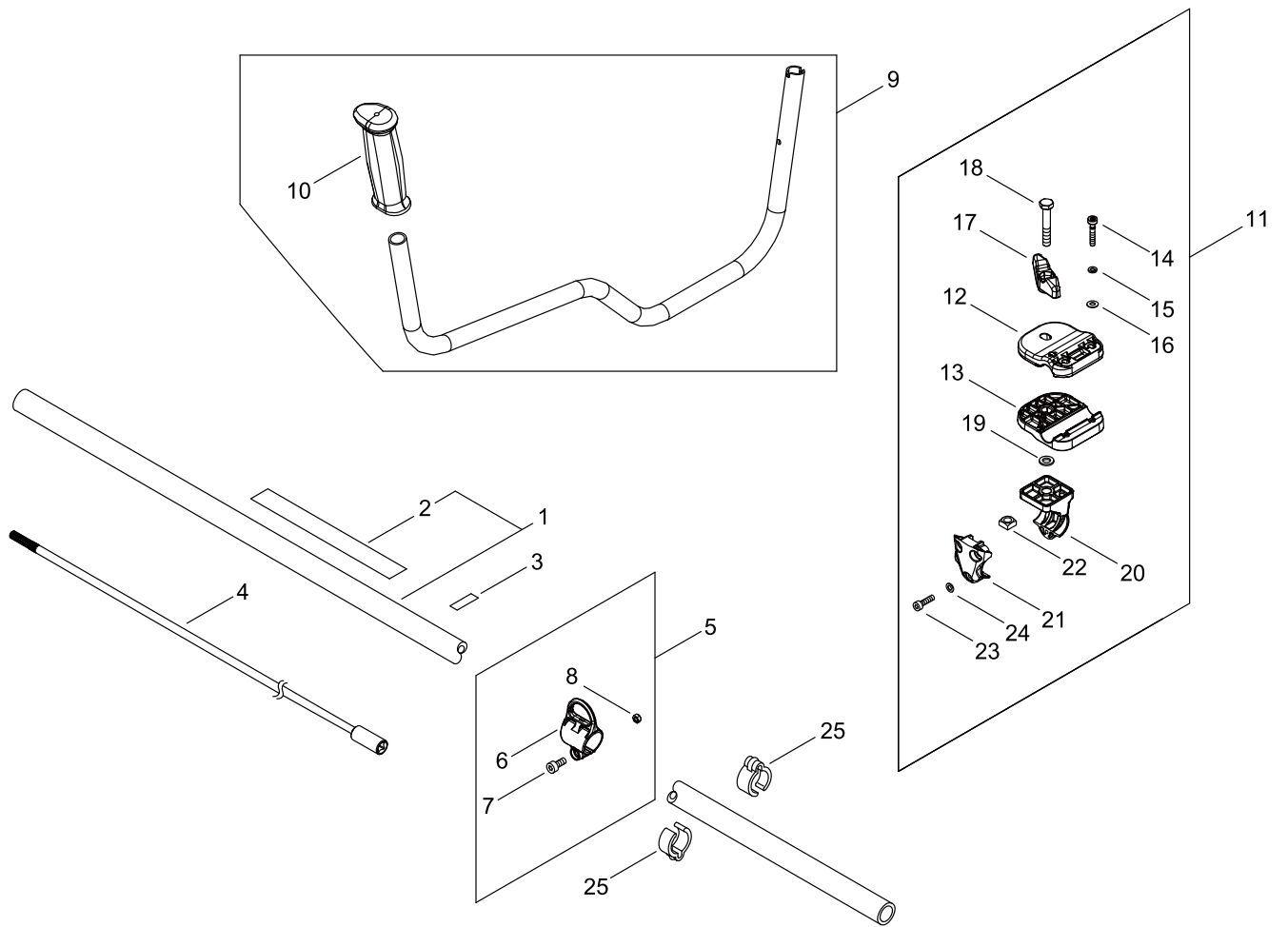

MAIN PIPE, HANDLE

Key No.	LV (+)	Parts Number	Parts Description	Qty	Standard	Class
1		P100-010840	MAIN PIPE ASY	1		C
2	+	X505-011600	LABEL,CAUTION	1	SHAFT CAUTION	D
3		890152-04930	LABEL, CAUTION	1		D
4		C504-001490	SHAFT, DRIVE	1	7*1586	C
5		P100-010550	HOOK ASY	1		D
6	+	C670-000240	HOOK,LIFTING	1		C
7	+	V805-000320	BOLT, TORX 5	1	TB-5*16 10.9	C
8	+	900500-00005	NUT	1	5	
9		P100-010560	HANDLE ASY	1		C
10	+	C403-000031	GRIP,HANDLE	1		C
11		P100-010570	FIXTURE HANDLE SET	1		D
12	+	C423-001090	FIXTURE, HANDLE	1	19	D
13	+	C423-001100	FIXTURE, HANDLE	1	19	D
14	+	V203-002500	BOLT,5	2	TB-5*30	C
15	+	900605-00005	WASHER, SPRING	2	5	
16	+	900620-00005	WASHER	2	5	
17	+	V299-000680	KNOB,FASTENER	1	M8	C
18	+	V205-001400	BOLT,8	1	M8*1.25*L50	C
19	+	900720-20007	O-RING	1	P-7	
20	+	C423-001110	FIXTURE, HANDLE	1		D
21	+	C423-001120	FIXTURE, HANDLE	1		D
22	+	900565-50008	NUT, SQUARE	1	8	
23	+	V805-000170	BOLT, TORX 5	3	TB-5*25 10.9	C
24	+	900600-00005	WASHER	1	5	
25		224924-52130	CLIP	2	25MM	C

Class : Consumable class

A:Fast moving parts B:Semi-fast moving parts C:Slow moving parts D:Order only as needed

CONTROL

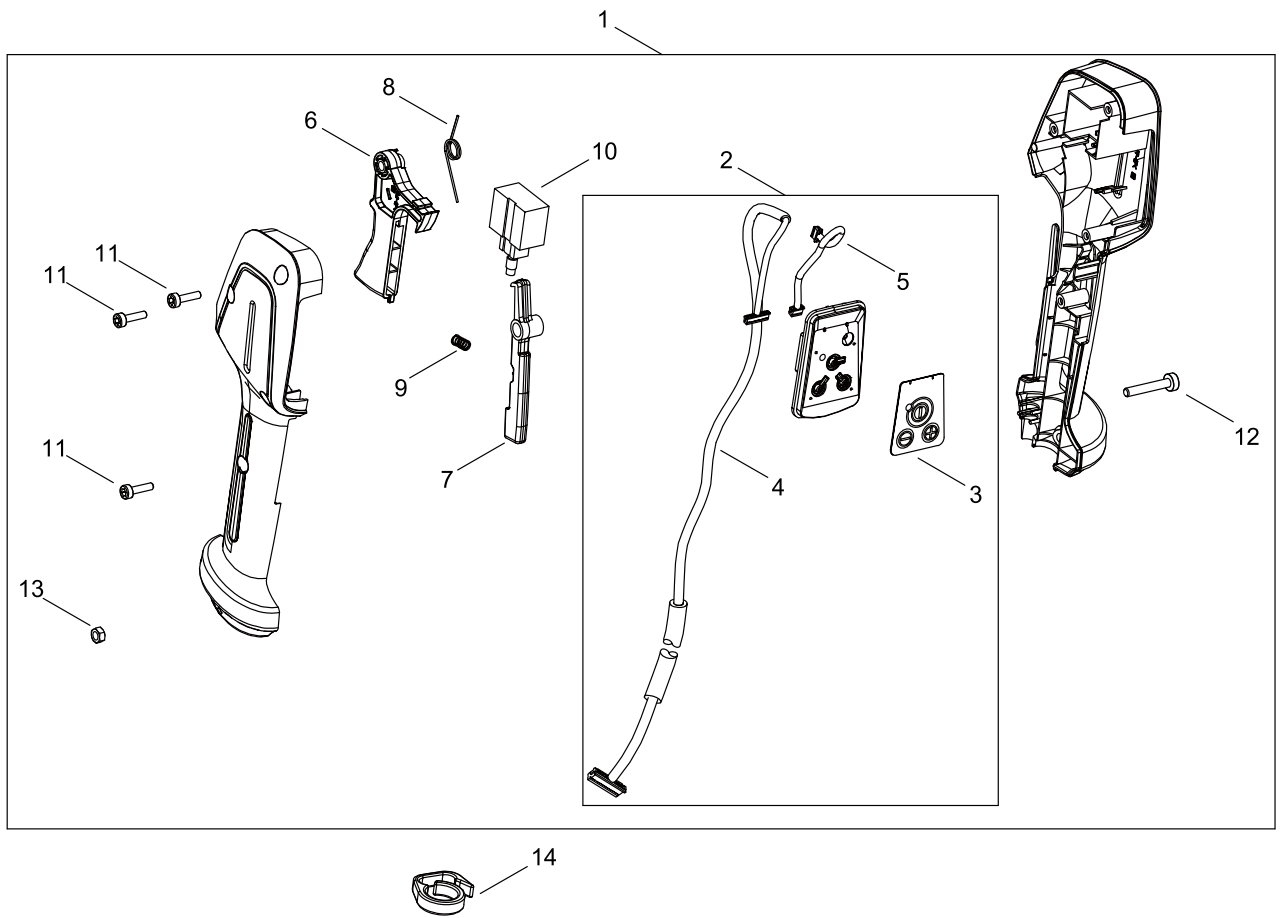

CONTROL

Key No.	LV (+)	Parts Number	Parts Description	Qty	Standard	Class
1		P100-010880	CONTROL LEVER ASY	1		C
2	+	A047-000470	BOARD,ASM CONTROL	1		D
3	++	X510-001290	LABEL,SWITCH	1		D
4	++	C130-001170	HARNESS,WIRE	1		D
5	++	C130-001160	HARNESS,WIRE	1		D
6	+	J361-000810	LEVER	1		D
7	+	C490-000030	LOCKOUT	1		C
8	+	V452-002010	SPRING,TORSION	1		B
9	+	V450-000860	COIL SPRING	1		B
10	+	G334-001830	SWITCH	1	G33407S0080	C
11	+	V804-000170	BOLT, TORX 4	4	TT-P ｽﾀｲﾄﾞ 4*16	C
12	+	V805-000050	BOLT, TORX 5	1	TB-5*30 10.9	C
13	+	900590-00005	NUT	1	5	
14		159112-09961	CLIP	1		C

Class : Consumable class

A:Fast moving parts B:Semi-fast moving parts C:Slow moving parts D:Order only as needed

ACCESSORIES

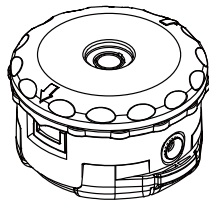
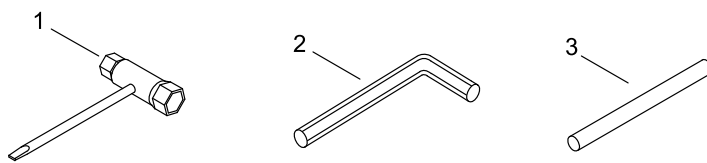

SF400/E1

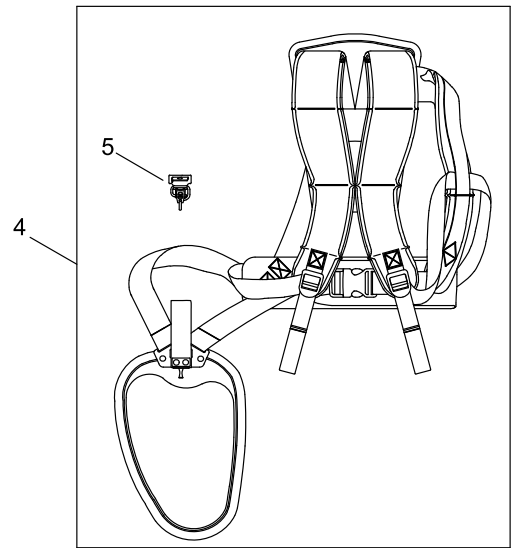

LBP-560-200

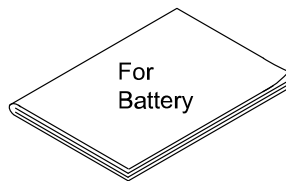
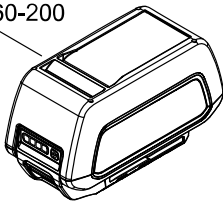

LCJQ-560D

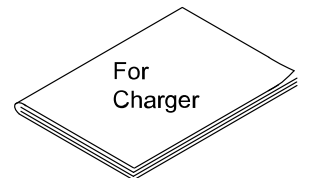
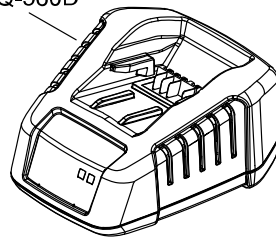

* Batteries and charger are handle as accessories instead of spare parts.
Please place an order of batteries and charger at the same time as unit order.

ACCESSORIES

Key No.	LV (+)	Parts Number	Parts Description	Qty	Standard	Class
1		X602-000020	TOOL,WRENCH	1	17*19 L200	D
2		X605-000060	TOOL,L WRENCH	1	80*30 T27 2-ENDS	D
3		X606-000080	TOOL,BAR	1	5*120	D
4		C062-000511	HARNESS, SHOULDER	1		B
5	+	P021-041300	HOOK ASSY	1		

Class : Consumable class

A:Fast moving parts B:Semi-fast moving parts C:Slow moving parts D:Order only as needed

NUMERICAL PARTS INDEX

Part No	Part description	Page	Part No	Part description	Page	Part No	Part description	Page
159112-09961	CLIP	8	C423-001110	FIXTURE, HANDLE	6	X503-015940	LABEL,MODEL	2
224924-52130	CLIP	6	C423-001120	FIXTURE, HANDLE	6	X505-011600	LABEL,CAUTION	6
610313-52132	FIXTURE,BLADE	4	C490-000030	LOCKOUT	8	X510-001290	LABEL,SWITCH	8
610313-52932	FIXTURE,BLADE	4	C504-001490	SHAFT, DRIVE	6	X602-000020	TOOL,WRENCH	10
610314-52130	PLATE, ADAPTER (L)	4	C534-001080	SHAFT, GEAR	4	X605-000060	TOOL,L WRENCH	10
610320-52130	NUT 10	4	C550-000551	SHIELD,BLADE	4	X606-000080	TOOL,BAR	10
610352-56830	PLATE, CUP	4	C552-000200	PLATE, SHIELD	4			
610434-50031	BOLT 8* 8	4	C554-000090	KNIFE, CORD	4			
699229-56830	PLATE, COVER	4	C670-000240	HOOK,LIFTING	6			
890152-04930	LABEL, CAUTION	6	G334-001830	SWITCH	8			
900220-04006	SCREW	4	J361-000810	LEVER	8			
900500-00005	NUT	6	P021-041300	HOOK ASSY	10			
900562-00005	NUT, LOCK	4	P021-054020	CASE,FAN ASY	2			
900565-00005	NUT, SQUARE	4	P100-004840	CASE,GEAR ASY	4			
900565-50008	NUT, SQUARE	6	P100-010520	SHIELD ASY	4			
900590-00005	NUT	8	P100-010550	HOOK ASY	6			
900600-00005	WASHER	6	P100-010560	HANDLE ASY	6			
900603-50008	WASHER	4	P100-010570	FIXTURE HANDLE SET	6			
900605-00005	WASHER, SPRING	6	P100-010830	SHIELD ASY	4			
900620-00005	WASHER	6	P100-010840	MAIN PIPE ASY	6			
900701-00009	RETAINING RING	4	P100-010880	CONTROL LEVER ASY	8			
900702-00025	RETAINING RING	4	V000-000260	GEAR SET, BEVEL	4			
900702-00032	RETAINING RING	4	V203-002500	BOLT,5	6			
900706-00012	RETAINING RING	4	V205-001400	BOLT,8	6			
900720-00012	O-RING	4	V299-000680	KNOB,FASTENER	6			
900720-20007	O-RING	6	V340-000180	WASHER	4			
900800-00609	BEARING, BALL	4	V450-000860	COIL SPRING	8			
900803-00609	BEARING, BALL	4	V452-001310	SPRING,TORSION	4			
900810-00629	BEARING, BALL	4	V452-002010	SPRING,TORSION	8			
900812-06201	BEARING, BALL	4	V804-000170	BOLT, TORX 4	2			
91316-04010	SCREW	4	V804-000170	BOLT, TORX 4	8			
A047-000450	BOARD,ASM CONTROL	2	V804-000190	BOLT, TORX 4	2			
A047-000470	BOARD,ASM CONTROL	8	V805-000050	BOLT, TORX 5	8			
A054-000330	MOTOR,ASM	2	V805-000130	BOLT, TORX 5	4			
A161-000440	DUCT, AIR	2	V805-000150	BOLT, TORX 5	4			
A539-000490	COVER,MOTOR	2	V805-000160	BOLT, TORX 5	2			
A575-000770	FIXTURE, MAIN PIPE	2	V805-000170	BOLT, TORX 5	2			
C062-000511	HARNES, SHOULDER	10	V805-000170	BOLT, TORX 5	4			
C130-001160	HARNES,WIRE	8	V805-000170	BOLT, TORX 5	6			
C130-001170	HARNES,WIRE	8	V805-000260	BOLT, TORX 5	4			
C145-000190	COVER,BATTERY	2	V805-000320	BOLT, TORX 5	6			
C146-000030	HOLDER,BATTERY	2	V806-000020	BOLT, TORX 6	4			
C403-000031	GRIP,HANDLE	6	X424-000080	FIXTURE,COVER	2			
C423-001090	FIXTURE, HANDLE	6	X424-000090	FIXTURE,COVER	2			
C423-001100	FIXTURE, HANDLE	6	X502-000390	LABEL,ECHO	2			