

DCS-2500T

Serial Number

35000001-35999999

Last updated date

27/Nov/2020

TABLE OF CONTENTS

MOTOR	1
CHAIN BRAKE	3
ACCESSORIES	5
OILER.....	7
GUIDE BAR, CHAIN	9
OPTION PARTS.....	11

MOTOR

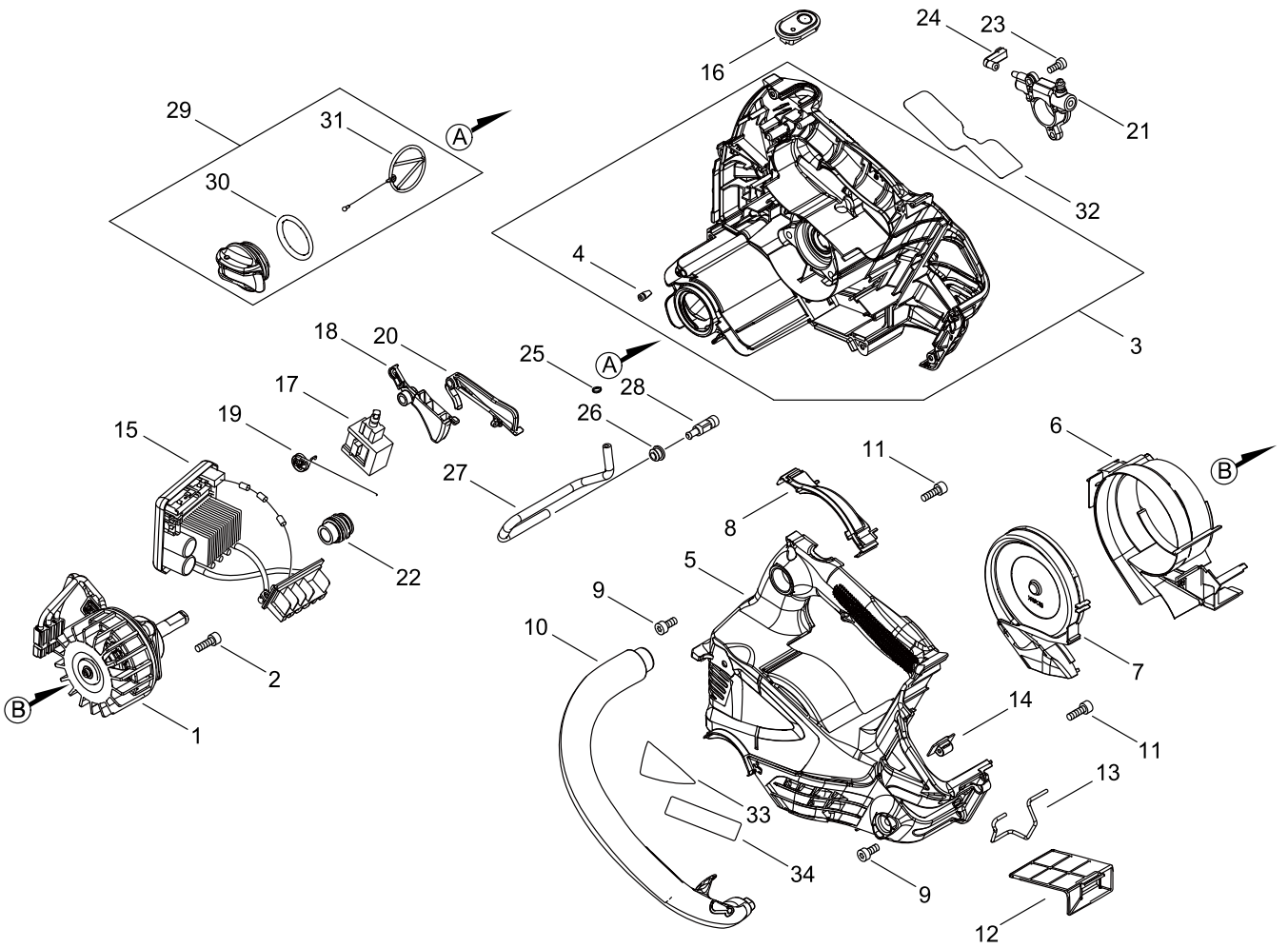

MOTOR

Key No.	LV (+)	Parts Number	Parts Description	Qty	Standard	Class
1		A054-000300	MOTOR,ASM	1		D
2		V805-000250	BOLT, TORX 5	3	TB-5*16 12.9	C
3		P100-009521	COVER,MOTOR ASY	1		C
4	+	436114-13930	VALVE, CHECK	1		B
5		A539-000480	COVER,MOTOR	1	F-SIDE	C
6		E103-001660	CASE,FAN	1	LARGE	C
7		E103-001670	CASE,FAN	1		C
8		A539-000460	COVER,MOTOR	1	SMALL	C
9		V804-000160	BOLT, TORX 4	6	TT-P ㄉ1 4*12	C
10		C400-001740	HANDLE, FRONT	1	GAI	C
11		V805-000000	BOLT, TORX 5	2	TT-5*16 DG 10.9	C
12		A226-002360	ELEMENT, AIR FILTER	1	PA6-MESH #30	A
13		C646-000160	RING, HARNESS	1	2.3	C
14		C626-000100	FIXTURE, HARNESS	1		D
15		A047-000420	BOARD,ASM CONTROL	1		D
16		A047-000430	SWITCH	1		D
17		G334-001830	SWITCH	1	G33407S0080	C
18		J361-000790	LEVER	1		
19		V452-001650	SPRING,TORSION	1		B
20		C490-000010	LOCKOUT	1		C
21		C022-000211	AUTO-OILER ASSEMBLY	1	OP-27C(B)	C
22		V652-000290	GEAR,WORM	1		B
23		V804-000160	BOLT, TORX 4	1	TT-P ㄉ1 4*12	C
24		V470-002400	PIPE	1		C
25		V490-001230	CLIP	1		C
26		132115-01462	GROMMET	1		C
27		V471-003311	PIPE	1	3*6*200	C
28		P021-050140	STRAINER, OIL ASY	1		
29		P100-004610	CAP,OIL ASY	1		
30	+	900720-20029	O-RING	1	P-29	
31	+	A365-000050	CONNECTOR,CAP	1		B
32		X505-011050	LABEL,CAUTION	1	SYMBOL	D
33		X543-005720	LABEL,MODEL	1	DCS-2500T	D
34		X502-000390	LABEL,ECHO	1	ECHO 72.5*15	D

Class : Consumable class

A:Fast moving parts B:Semi-fast moving parts C:Slow moving parts D:Order only as needed

CHAIN BRAKE

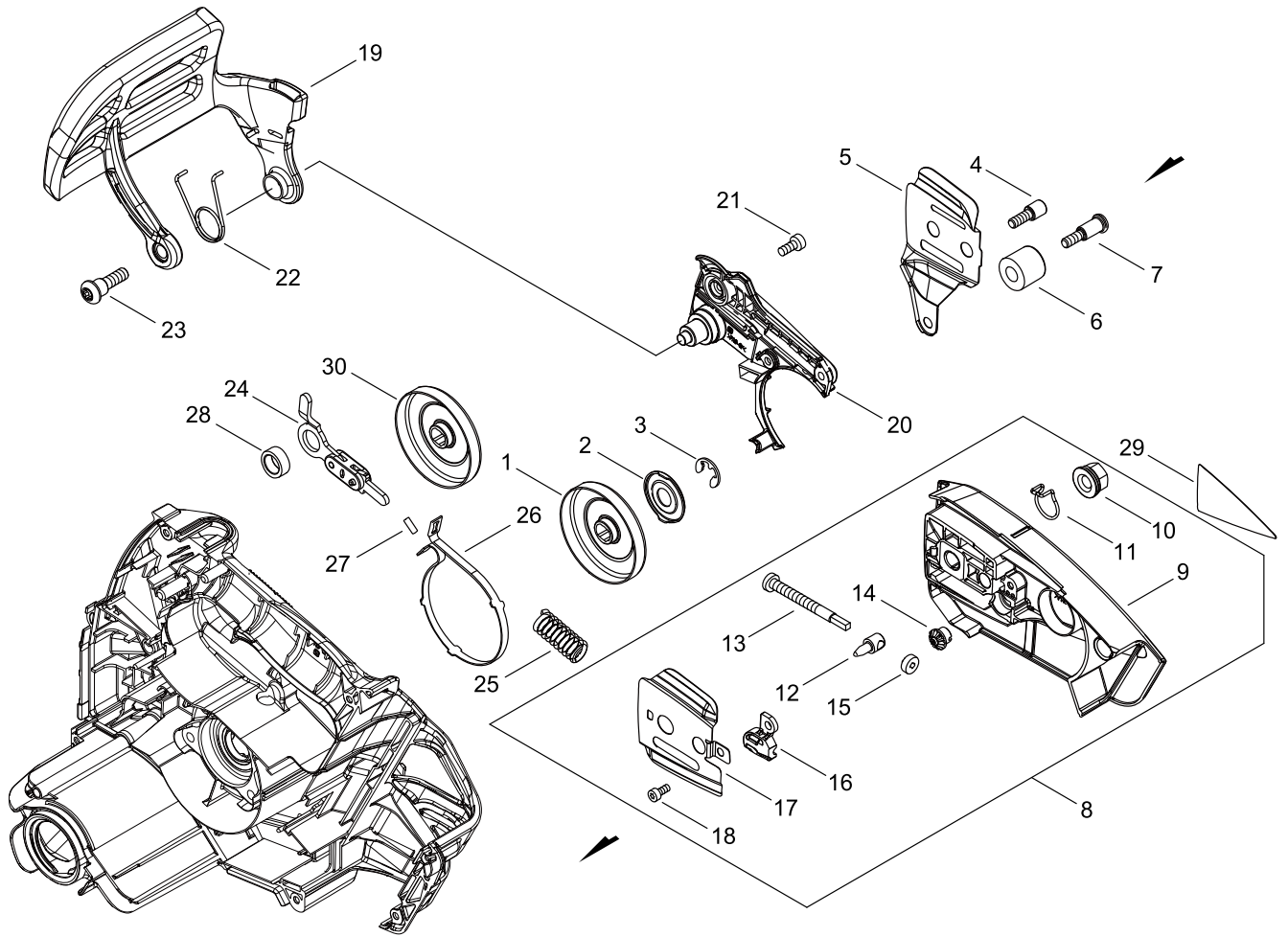

CHAIN BRAKE

Key No.	LV (+)	Parts Number	Parts Description	Qty	Standard	Class
1		A556-001920	DRUM, CLUTCH	1	3/8	B
2		V307-000620	WASHER,CIRCULAR 10	1	10*28.5*3.5(0.8)	C
3		V583-000440	RING	1	8.1 T1.2	C
4		V203-002280	BOLT,5	1		C
5		C305-000511	PLATE,SPROCKET GUARD	1	T0.3	C
6		C310-000140	CATCHER, CHAIN	1		B
7		V203-002260	BOLT,5	1		C
8		P100-009530	GUARD, SPROCKET ASY	1		
9	+	C300-001220	GUARD, SPROCKET	1		C
10	+	V265-000550	NUT,8	1		C
11	+	C649-000420	HOOK	1		D
12	+	C309-000110	TENSIONER,CHAIN	1		C
13	+	V203-000041	BOLT,5	1		C
14	+	V651-001060	GEAR,BEVEL	1		D
15	+	V651-000011	GEAR,BEVEL	1		D
16	+	V355-000840	COLLAR,8	1		C
17	+	C305-000521	PLATE,SPROCKET GUARD	1	T0.3	C
18	+	V804-000160	BOLT, TORX 4	1	TT-P 4*12	C
19		C320-000610	LEVER, BRAKE	1		C
20		C345-000730	COVER,BRAKE	1		C
21		V804-000160	BOLT, TORX 4	3	TT-P 4*12	C
22		V452-001940	SPRING,TORSION	1	1.6	B
23		V203-002270	BOLT,5	1		C
24		C334-000340	CONNECTOR, BRAKE	1		C
25		V450-002400	SPRING,COMPRESSION	1	Φ2.5	B
26		C328-000360	BAND, BRAKE	1		C
27		93050-30080	ROLLER	1	3*8	
28		V355-000860	COLLAR,8	1		C
29		X502-001230	LABEL,ECHO	1		D
30		A556-001910	DRUM, CLUTCH	1	1/4	B

Class : Consumable class

A:Fast moving parts B:Semi-fast moving parts C:Slow moving parts D:Order only as needed

ACCESSORIES

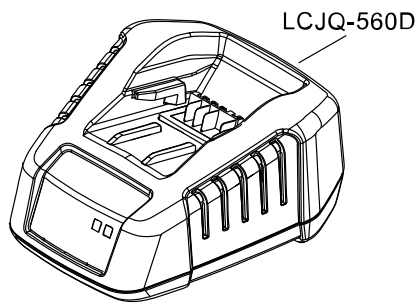
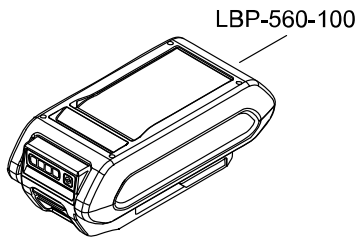
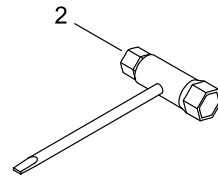
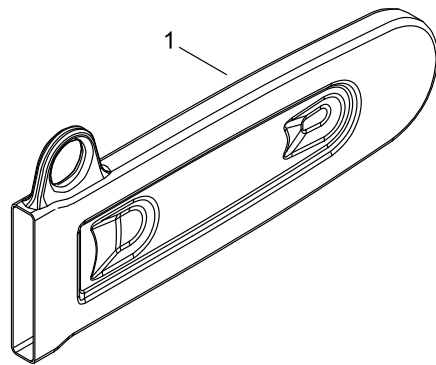

* Batteries and charger are handle as accessories instead of spare parts.
Please place an order of batteries and charger at the same time as unit order.

ACCESSORIES

Key No.	LV (+)	Parts Number	Parts Description	Qty	Standard	Class
1		X490-000990	SCABBARD,CHAIN	1		D
2		X602-000080	TOOL,WRENCH	1	13*19 L180	D

Class : Consumable class

A:Fast moving parts B:Semi-fast moving parts C:Slow moving parts D:Order only as needed

OILER

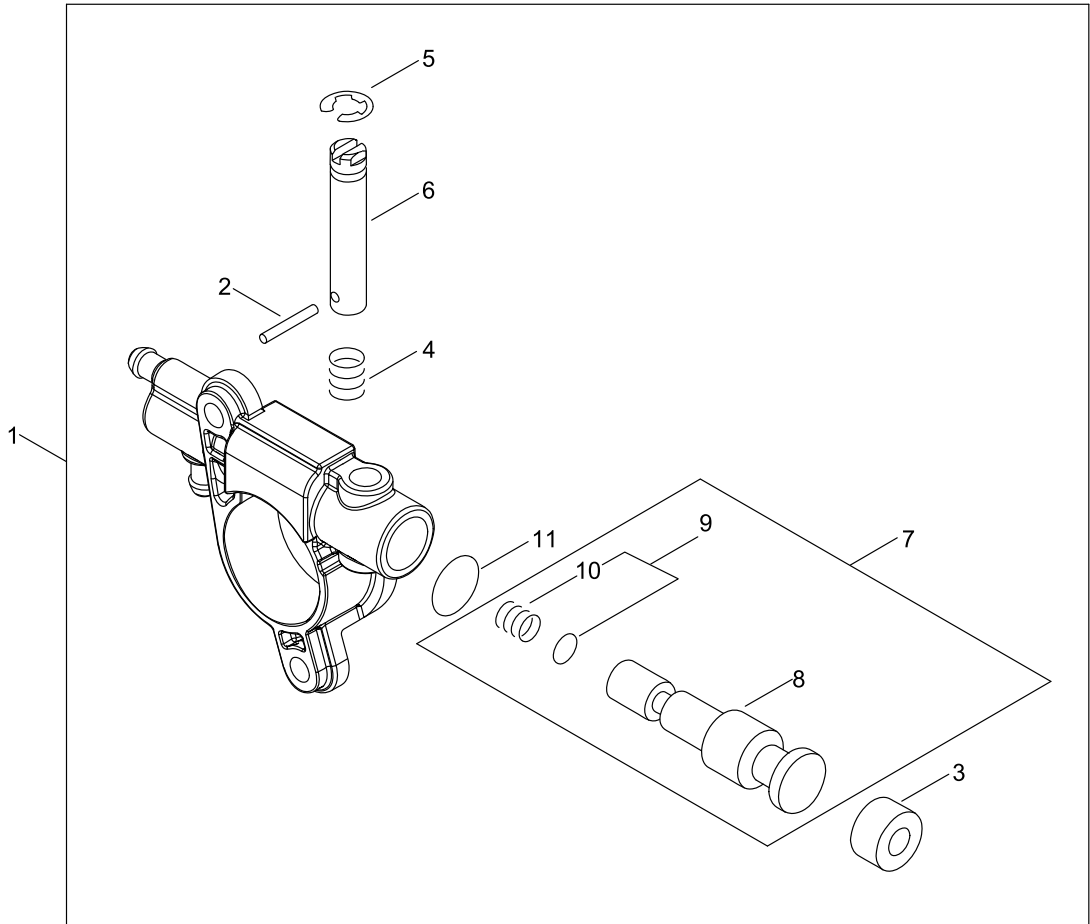



OILER

Key No.	LV (+)	Parts Number	Parts Description	Qty	Standard	Class
1		C022-000211	AUTO-OILER ASSEMBLY	1	OP-27C(B)	C
2	+	P003-002180	PIN, SPRING	1		
3	+	437062-38330	CAP, OIL PUMP	1		
4	+	437015-37330	SPRING	1		
5	+	123127-15030	RING	1		
6	+	P003-005430	NEEDLE-ADJ	1		D
7	+	P200-000390	PLUNGER SHAFT KIT	1		
8	++	P003-005990	SHAFT ASY-PLUNGER	1		
9	++	P200-000490	SPRING WASHER KIT	1		
10	+++	P003-006000	SPRING	1		
11	+	P003-005420	WASHER	1		

Class : Consumable class

A:Fast moving parts B:Semi-fast moving parts C:Slow moving parts D:Order only as needed

GUIDE BAR, CHAIN

Pitch ピッチ (inch) (mm)	Gauge ゲージ (inch) (mm)	Length 長さ (cm)	Guide Bar ガイドバー		Saw Chain ソーチェーン		Hard Nose ハード ノーズ	Sprocket Nose スプロケット ノーズ	File Tool ファイル ツール	Grip グリップ
			Key №	Type 形式	Key №	Type 形式				
3/8 9.53	0.050 1.27	25	A1	C25S91-40SL- ET	A2	91PX-40E		●	3	4
1/4 6.35	0.043 1.09	25	B1	C25HA4-60CL- ED	B2	A4S-60E	●			
1/4 6.35	0.043 1.09	20	C1	C20HA4-52CL- ED	C2	A4S-52E	●			

GUIDE BAR, CHAIN

Key No.	LV (+)	Parts Number	Parts Description	Qty	Standard	Class
A1		X121-000003	BAR,GUIDE 25	1	C25S91-40SL- ET	A
A2		X221-000100	CHAIN,SAW	1	91PX-40E	A
B1		X101-000210	BAR,GUIDE 25	1	C25HA4-60CL- ED	A
B2		X201-000020	CHAIN,SAW	1	A4S-60E ECHO	A
C1		X100-000070	BAR,GUIDE 20	1	C20HA4-52CL- ED	A
C2		X200-000020	CHAIN,SAW	1	A4S-52E ECHO	A
3		X620-000080	TOOL,FILE	1	3.5*246	D
4		X622-000000	GRIP	1	D3.5-4.0	D

Class : Consumable class

A:Fast moving parts B:Semi-fast moving parts C:Slow moving parts D:Order only as needed

OPTION PARTS

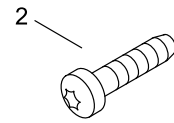
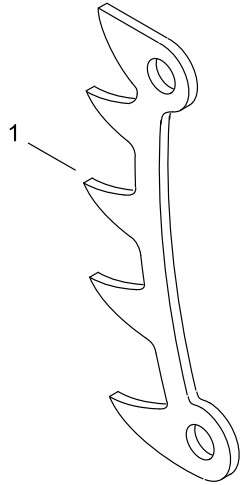

OPTION PARTS

Key No.	LV (+)	Parts Number	Parts Description	Qty	Standard	Class
1		C304-000000	SPIKE	1		C
2		V805-000240	BOLT, TORX 5	2	TT-5*12 DG 10.9	C

Class : Consumable class

A:Fast moving parts B:Semi-fast moving parts C:Slow moving parts D:Order only as needed

NUMERICAL PARTS INDEX

Part No	Part description	Page	Part No	Part description	Page
123127-15030	RING	8	P100-009521	COVER,MOTOR ASY	2
132115-01462	GROMMET	2	P100-009530	GUARD, SPROCKET ASY	4
436114-13930	VALVE, CHECK	2	P200-000390	PLUNGER SHAFT KIT	8
437015-37330	SPRING	8	P200-000490	SPRING WASHER KIT	8
437062-38330	CAP, OIL PUMP	8	V203-000041	BOLT,5	4
900720-20029	O-RING	2	V203-002260	BOLT,5	4
93050-30080	ROLLER	4	V203-002270	BOLT,5	4
A047-000420	BOARD,ASM CONTROL	2	V203-002280	BOLT,5	4
A047-000430	SWITCH	2	V265-000550	NUT,8	4
A054-000300	MOTOR,ASM	2	V307-000620	WASHER,CIRCULAR 10	4
A226-002360	ELEMENT, AIR FILTER	2	V355-000840	COLLAR,8	4
A365-000050	CONNECTOR,CAP	2	V355-000860	COLLAR,8	4
A539-000460	COVER,MOTOR	2	V450-002400	SPRING,COMPRESSION	4
A539-000480	COVER,MOTOR	2	V452-001650	SPRING,TORSION	2
A556-001910	DRUM, CLUTCH	4	V452-001940	SPRING,TORSION	4
A556-001920	DRUM, CLUTCH	4	V470-002400	PIPE	2
C022-000211	AUTO-OILER ASSEMBLY	2	V471-003311	PIPE	2
C022-000211	AUTO-OILER ASSEMBLY	8	V490-001230	CLIP	2
C300-001220	GUARD, SPROCKET	4	V583-000440	RING	4
C304-000000	SPIKE	12	V651-000011	GEAR,BEVEL	4
C305-000511	PLATE,SPROCKET GUARD	4	V651-001060	GEAR,BEVEL	4
C305-000521	PLATE,SPROCKET GUARD	4	V652-000290	GEAR,WORM	2
C309-000110	TENSIONER,CHAIN	4	V804-000160	BOLT, TORX 4	2
C310-000140	CATCHER, CHAIN	4	V804-000160	BOLT, TORX 4	4
C320-000610	LEVER, BRAKE	4	V805-000000	BOLT, TORX 5	2
C320-000610	LEVER, BRAKE	4	V805-000240	BOLT, TORX 5	12
C328-000360	BAND, BRAKE	4	V805-000250	BOLT, TORX 5	2
C334-000340	CONNECTOR, BRAKE	4	X100-000070	BAR,GUIDE 20	10
C345-000730	COVER,BRAKE	4	X101-000210	BAR,GUIDE 25	10
C400-001740	HANDLE, FRONT	2	X121-000003	BAR,GUIDE 25	10
C490-000010	LOCKOUT	2	X200-000020	CHAIN,SAW	10
C626-000100	FIXTURE, HARNESS	2	X201-000020	CHAIN,SAW	10
C646-000160	RING, HARNESS	2	X221-000100	CHAIN,SAW	10
C649-000420	HOOK	4	X490-000990	SCABBARD,CHAIN	6
E103-001660	CASE,FAN	2	X502-000390	LABEL,ECHO	2
E103-001670	CASE,FAN	2	X502-001230	LABEL,ECHO	4
G334-001830	SWITCH	2	X505-011050	LABEL,CAUTION	2
J361-000790	LEVER	2	X543-005720	LABEL,MODEL	2
P003-002180	PIN, SPRING	8	X602-000080	TOOL,WRENCH	6
P003-005420	WASHER	8	X620-000080	TOOL,FILE	10
P003-005430	NEEDLE-ADJ	8	X622-000000	GRIP	10
P003-005990	SHAFT ASY-PLUNGER	8			
P003-006000	SPRING	8			
P021-050140	STRAINER, OIL ASY	2			
P100-004610	CAP,OIL ASY	2			